

IRC ANALYSIS OF INSULATION SYSTEMS

*František KOVAL, **Roman CIMBALA

*Department of Electro-Power Engineering, Faculty of Electrical Engineering and Informatics, Technical University of Košice, Mäsiarska 74, 042 00 Košice, tel. 055/602 3560, E-mail: frantisek.koval@tuke.sk

**Department of Electro-Power Engineering, Faculty of Electrical Engineering and Informatics, Technical University of Košice, Mäsiarska 74, 042 00 Košice, tel. 055/602 2212, E-mail: roman.cimbala@tuke.sk

SUMMARY

This article describes insulation systems of electrical equipments, degradation of this system and temperature stress of Remikaflex insulation. Also describes polarization processes in insulation and how does change this processes due to degradation. In addition deals with monitoring of dielectric properties by Isothermal Relaxation Current-analysis (IRC-analysis) and finally were displayed diagrams of times and currents depend on degradation time and we made conversion of dissipation factor to frequency domain through parameters we got by IRC-analysis.

Keywords: IRC-Analysis, dielectric diagnostic, ageing in Remikaflex material, destruction free diagnostic

1. INTRODUCTION

Insulation system is the most sensitive part of every electrical mechanism. Damage of this system, result in secondary impact to entire manufacturing processes mainly in big production factories.

Insulation degrades over a period of time because of various stresses affect upon it during its normal working life. The basic initiators for insulation degradation are electrical stress, mechanical stress, chemical attack, thermal stress and environmental contamination. Normal cycles of operation lead to aging through these mechanisms [1]. Interaction various factors together may significantly speed up the degradation processes.

2. DIAGNOSTIC OF INSULATION SYSTEM

No insulation is perfect, therefore a certain magnitude of current does flow through it. This current may be insignificantly small but for most practical purposes it is the basis of insulation testing [1].

There are changes of the material structure due to degradation. This changes lead to change of the insulation properties. No equation or relationship exists to determine exactly the rest life of the insulation. However, in present day, many methods exist through which we can observe changes in the insulation structure due to ageing and following the results we can estimate insulation rest life.

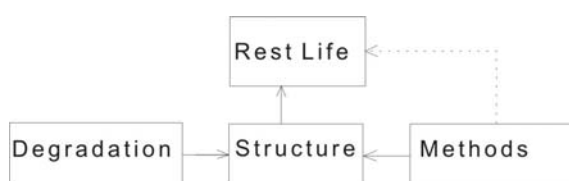

Fig. 1 Degradation of material

2.1. IRC analysis of Remikaflex 45.004 insulation

Remikaflex 45.004 is in normal temperature very elastic, thermosetting insulation material with great dielectric properties. Material is made from calcined mica paper of Remik (muscovite), from glass cloth and from polyethylenetereflat's foil. Everything is bind together by epoxy.

Remikaflex 45.004 is used to insulation coil ends of high-voltage equipments working in temperature class F (155°C). Moreover is used to insulation copper conductors and conductions [2].

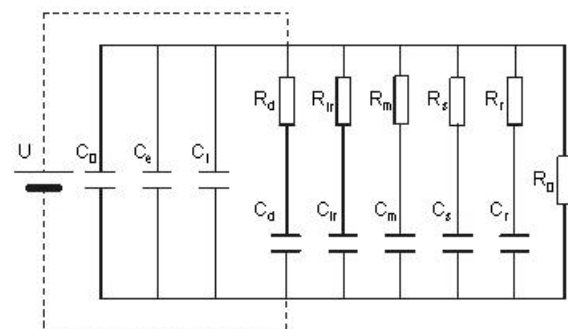

Fig. 2 Substitution diagram of dielectric

Isothermal Relaxation Current-analysis (IRC-analysis) is one of the DC methods which offer destruction free possibility to investigate the degradation processes in the material. The insulation ageing status can be determined by measuring the relaxation currents in the time domain and in combination with intelligent software we can get elements of dielectric substitution diagram (fig.2) according [3,4]:

$$R_i = \frac{U_0}{I_{mi}}, \quad C_i = \frac{T_i}{R_i} \quad (1)$$

The dielectric is described by an RC network (fig.2) consisting of an ohmic resistor R_0 due to the

conductivity of the insulation system, the capacitance C_0 of the insulation system and the RC series branches R_i, C_i , which represent the time-depend polarization of the dielectric. R_d, C_d represents dipole polarization, R_{Ir}, C_{Ir} represents ion relaxation polarization, R_m, C_m represents migration polarization, R_s, C_s represents spontaneous polarization, R_r, C_r represents resonance polarization and capacitances C_e, C_i represents electronic and ionic polarization. There are no resistances R_e, R_i because this type of polarization has no dielectric losses [5].

In insulation system can occur more than 7 polarization processes how is describes in fig.2. However, we did just 1000 sec. measurements and in that time we could measure by IRC-analysis only 7 types of polarizations.

Polarization current presents equation (2).

$$i_i(t) = \frac{U_0}{R_0} + \sum_{i=1}^n I_{mi} \exp\left(\frac{-t}{T_i}\right) \quad (2)$$

Where: U_0 – applied DC voltage (100V),
 I_{mi} – currents in single branches,
 T_i – relaxation times constant.

Figure 3 shows diagram of polarization and depolarization current.

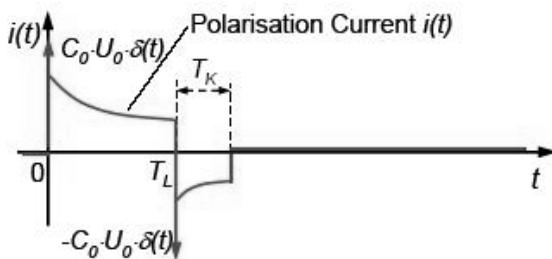

Fig. 3 Diagram of polarization and depolarization currents

2.2. Diagram of relaxation currents of Remikaflex insulation depend on degradation

Figure 4 shows diagram of polarization current new Remikaflex insulation. Sample of this insulation was placed in electrode system. Then the electrode system was connected to test voltage (100V) by Keithley 617 electrometer and the sample was subjected to affect of this electrical field for 1000 seconds. Keithley 617 was connected to computer through IEEE 488.2 interface. By means of software we got the currents I_{mi} in single branches of substitution diagram and the times T_i which represents single actions. RC values we can calculation according equation (2).

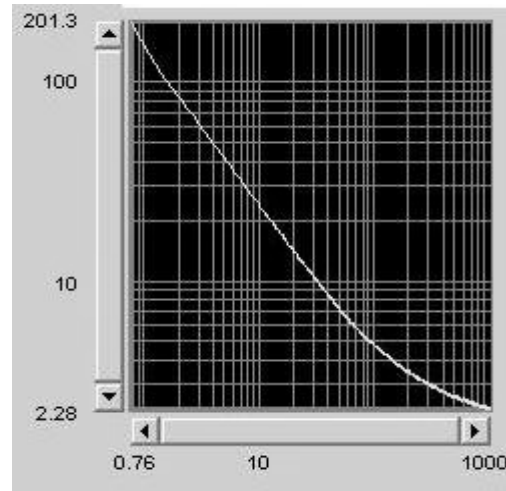

Fig. 4 Polarization current of new Remikaflex insulation

Figures 5 and 6 shows diagrams of time and currents when software calculates only with one type of polarization. Diagrams compare changes of the times T_1 and currents I_{m11}, I_0 depending on degradation time which was zero hour (new sample); 24; 76.2; 183.6; 404.6; 859.1 and 1794.3 hours. Remikaflex samples were subjected to temperature stress (186°C) during those times. Conducting current represents I_0 .

Figures 7 and 8 shows diagrams of times and currents when software calculates with three types of polarizations and figures 9 and 10 shows diagrams when software calculates with 6 types of polarizations.

We didn't compare seventh approximation because we've got negative I_{7i} at 24 hours aged sample and at 859.1 hours aged sample what wasn't right values.

We also did similar tests with Relanex 45.011 insulation samples which are used for insulation of electrical rotating machines. Diagrams and results will be presented at next publication.

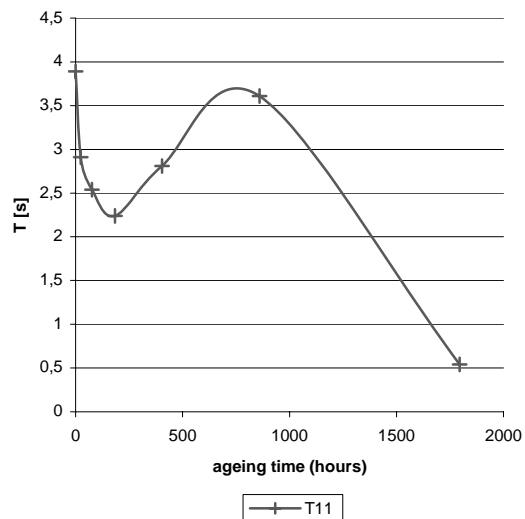

Fig. 5 First approximation of T_{11}

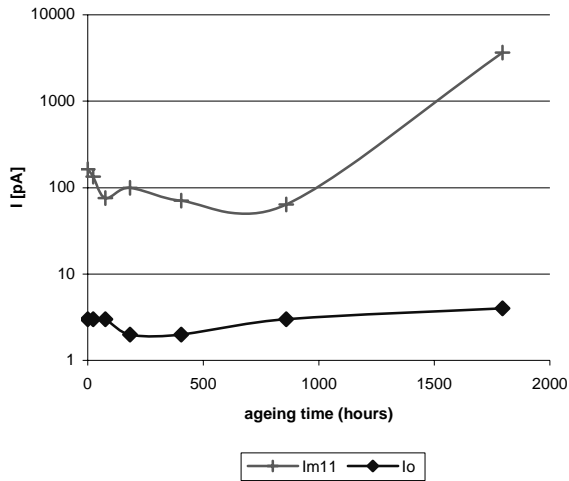

Fig. 6 First approximation of I_{m11} , I_0

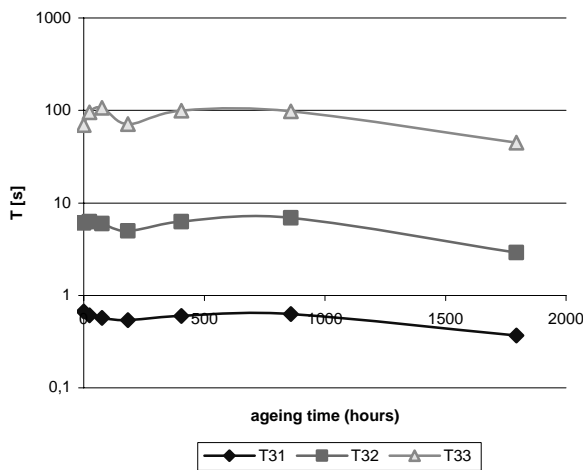

Fig. 7 Third approximation of T_{31} , T_{32} , T_{33}

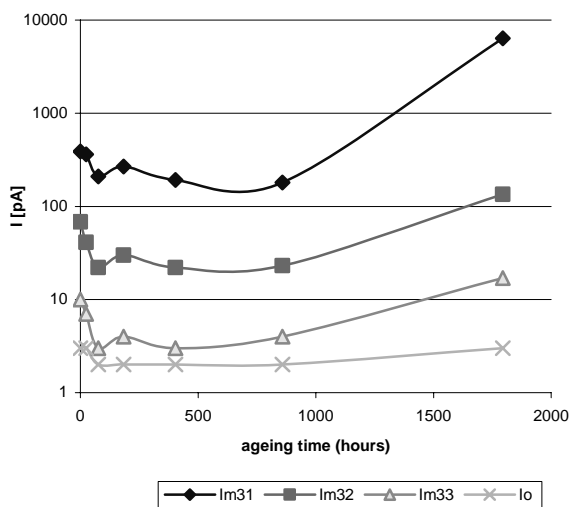

Fig. 8 Third approximation of I_{m31} , I_{m32} , I_{m33} , I_0

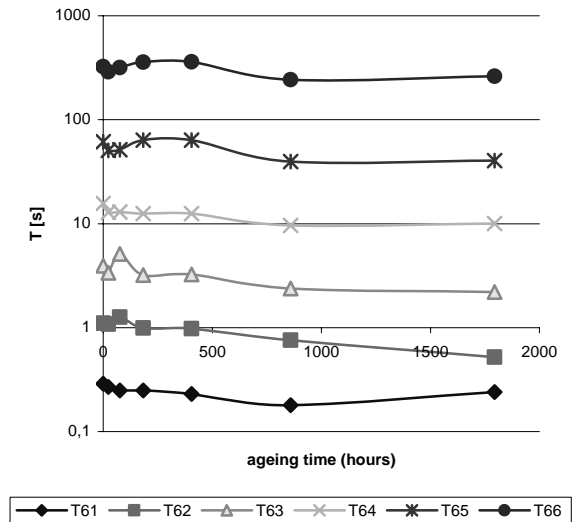

Fig. 9 Sixth approximation of T_{6i}

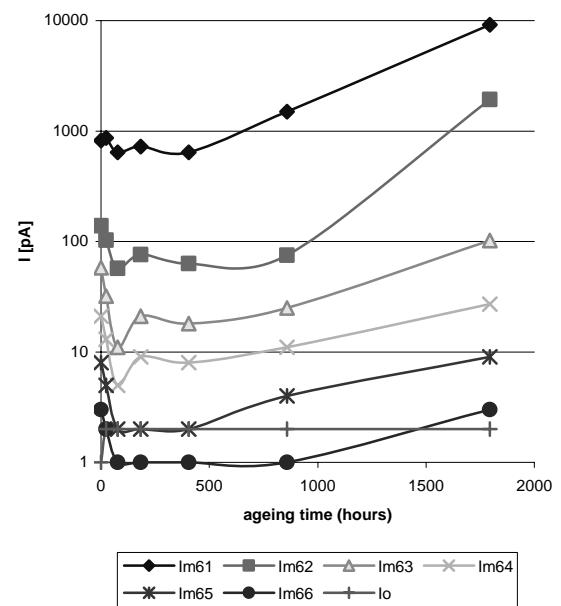

Fig. 10 Sixth approximation of I_{m6i} , I_0

2.3. Dissipation factor $\tan \delta$

The admittance Y of the RC model of a dielectric is:

$$\underline{I}(\omega) = \underline{Y} \cdot \underline{U}(\omega)$$

$$\underline{Y} = \frac{1}{R_0} + j\omega C_0 + \sum_{i=1}^N \frac{j\omega C_i}{1 + j\omega R_i C_i} = \quad (3)$$

$$= \frac{1}{R_0} + \sum_{i=1}^N \frac{(\omega R_i C_i)^2}{R_i (1 + (\omega R_i C_i)^2)} + j\omega \left[C_0 + \sum_{i=1}^N \frac{C_i}{1 + (\omega R_i C_i)^2} \right]$$

Then the dissipation factor can be easily derived out of the admittance according to equations (3)

$$\tan \delta = \frac{\operatorname{Re}\{Y\}}{\operatorname{Im}\{Y\}} = \frac{\frac{1}{R_0} + \sum_{i=1}^N \frac{(\omega R_i C_i)^2}{R_i (1 + (\omega R_i C_i)^2)}}{\omega C_0 + \sum_{i=1}^N \frac{\omega C_i}{1 + (\omega R_i C_i)^2}} \quad (4)$$

By equation (4) we can conversion $\tan \delta$ into frequency domain. Parameters R_i , C_i , R_0 and C_0 we've got by IRC-analysis and $\omega = 2\pi f$. If we will change the frequency in equation 4, then we can observe how does dissipation factor is changing in dependence on frequency. Figure 11 shows diagram of dissipation factor new Remikaflex sample at 0.001; 0.1; 0.2; 0.3; 0.4; 0.6; 0.8 and 1 hertz.

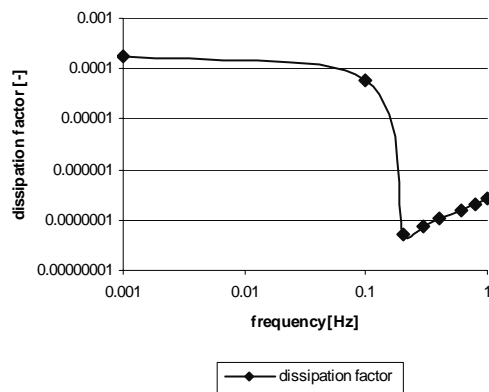

Fig. 11 Diagram of dissipation factor at sixth approximation

3. CONCLUSION

In general is known that new insulations material needs some time for curing. After this time the material starts degradation. That's the reason why our diagrams are unsymmetrical in a beginning.

We didn't test just one sample at single ageing time. Diagrams of each samples what we tested at the same degradation time was similar. We compared just one sample from every degradation time. The parameters what we've got are able to monitoring degradation processes in insulation systems due to temperature stress and results are suitable for next investigation.

This work was supported by scientific Grand Agency of the ministry of Education of Slovak Republic and the Slovak Academy of Sciences under the projects VEGA No. 1/3142/06 and APVV-20-006005.

REFERENCES

- [1] Hanif, M: Principles and applications of insulation testing with DC, IEP-SAC Journal 2004-2005, Saudi Arabia.
- [2] Ohebné slidové pásy Remikaflex 45.004, EIT catalog, 19.3 2003, pp. 1/1
- [3] M. Beigert, H.-G. Kranz, "Destruction Free Ageing Diagnosis of Power Cable Insulation Using the Isothermal Relaxation Current Analysis," IEEE ISEI, Pittsburgh, USA, pp. 94
- [4] G. Hoff, H.-G. Kranz, "Isothermal Relaxation Current Analysis: A New Non-destructive Diagnostic Tool for Polymeric Power Distribution Cables" April 1999 IEEE / PES Panel on Diagnostic Measurement Techniques for Power Cables, New Orleans, USA
- [5] W.S. Zaengl; Dielectric Spectroscopy in Time and Frequency Domain for HV Power Equipment (Transformers, Cables etc.); 12th ISH, Bangalore India, Aug. 2001

BIOGRAPHIES

František Koval' was born in 1980. In 2005 he graduated (MSc.) with distinction at the department of Electric Power Engineering of the Faculty of Electrical Engineering and Informatics at Technical University in Košice. Since 2005 he is studying as a PhD. student at the Technical University. His research interests are in the thermal degradation of solid insulation systems.

Roman Cimbala was born in Košice, Slovakia, in 1962. He graduated in electrical power engineering, field of generation and transmission of electrical energy, Faculty of Electrical Engineering and Informatics, Technical University Košice in 1986. He received the Ph.D. degree electric power engineering from Slovak Technical University in Bratislava in 1994, and associate professor degree from Technical University Košice in power engineering diagnostics in 1998.

From 1986 to 1990 he served as a Research Assistant at Department of High Voltage Engineering. Since 1990 he is a teacher. From 1991 to 1995 and in 2003 he was the head of this department. Now he is a head of High Voltage Division of Department of Electric Power Engineering at same University. Now he is a vicdean of the Faculty. He is a member of Working Group "Insulation Diagnostics" and invited member of Working Group "Electrostatics". He is a member of Slovak Commission for Technical Normalization, Slovak Association for Technical Diagnostics.

He is personally interested in diagnostics of high voltage insulation systems, especially in isothermal relaxation current analysis.