

## VOLTAGE IN ELECTRIC POWER SYSTEM WITH HIGH PHOTO VOLTAIC CELLS PENETRATION

Pavla HEJTMÁNKOVÁ, Jan ŠKORPIL

Department of Power Engineering and Ecology, Faculty of Electrical Engineering,  
West Bohemia University in Plzeň, Sady Pětatřicátníků 14, 304 16 Plzeň, Czech Republic, tel.: 00420 37763 4321,  
E-mail: hejtman@kee.zcu.cz, skorpil@kee.zcu.cz

### SUMMARY

Small, distributed generation (DG) technologies such as micro-turbines, photovoltaic (PV) and fuel cells are gaining wide interest because of rapid advances in technologies. The deployment of these generation units on distribution networks could potentially lower the cost of power delivery by placing energy sources nearer to the demand centres. The capacity of the devices ranges from 1 kW to 2 MW in power level.

PV systems can either be stand-alone, or grid-connected. The main difference between these two basic types of systems is that in the latter case the PV system produces power in parallel with the electrical utility and can feed power back into the utility grid if the onsite load requirement does not need all of the output from the PV system installed. The instantaneous power production from PV in the near future will often exceed the instantaneous power consumption in residential areas with a high concentration of PV systems. The power flow backwards through the MV/LV transformers, i.e. the power flows from the LV network to the medium voltage (MV) network will increase. There is need to know the impact of the backward power flow to the Electric power system (EPS) and to set the upper limits to of PV amount that can be fed into a power system without causing problems to the power systems and find the possibilities of stretching the limits.

**Keywords:** Photovoltaic power generation, Grid interconnection, Utility distribution system, Penetration level, Voltage limits, Distributed generation

### 1. INTRODUCTION

Distributed energy resources (DER) refers to a variety of small, modular electricity-generating or storage technologies that are located close to the load they serve. There are many types of DER [4] which can be used for power supply – heat or electric. If we assume as a final product electric power from DER, the produced electricity can covers the whole costumers load or the power output can be the higher or less one. In these cases, the power output has to be combined with a outside power EPS supplying possibility. The role of PV technology, as one of the perspective type of DG, is growing up. In order we can decide which PV operation state and interconnection to EPS is suitable [2], there is need to know the PV properties and its influence on EPS operation.

### 2. LOAD PLACING

Regarding to the load place and the interconnection to the power supply system, the load (supply) or DG systems based on PV generators can be divided to:

- **Stand alone** (SAPV systems) – grid off
- **Grid on** (IPV) – interconnected to EPS

**Stand-alone PV systems** are usually installed where it is more economic to use PV than any other form of power supply.

These types of PV generations can be separate to a few applications (Fig. 1) in depending on the utilisation purpose:

- **Small SAPV DC systems**
- **SAPV DC-AC system**
- **SAPV DC-AC battery system**

They can provide the power for domestic or other purposes.

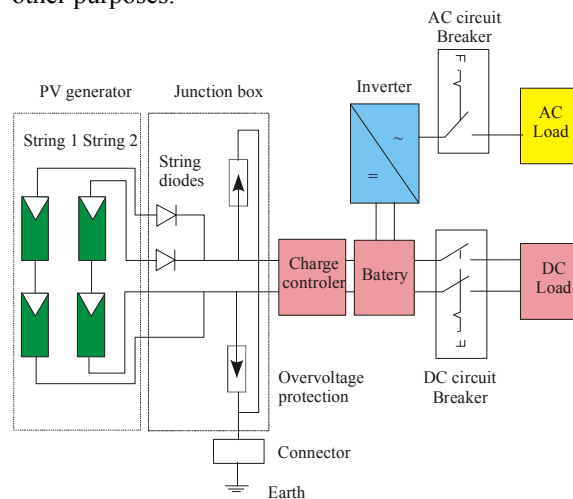

Figure 1. Grid on PV systems

Off-grid domestic systems provide electricity to households and villages that are not connected to the utility grid. They provide electricity for lighting, refrigeration and other low power loads and have been installed worldwide, particularly in developing countries, where they are often the most appropriate technology to meet the energy demands of off-grid communities. Off-grid domestic systems generally offer an economic alternative to extending the electricity distribution grid at distances of more than 1 or 2 km from existing power lines.

*Off-grid non-domestic installations* were the first commercial application for terrestrial PV systems. They provide power for a wide range of professional applications, such as telecommunication, water pumping, vaccine refrigeration, navigational aids, aeronautical warning lights and meteorological recording equipment. These are applications where small amounts of electricity have a high value, thus making PV commercially cost competitive with other small generating sources. There are the large market possibilities for not only for developing countries but for industrialised countries too.

The possibility of SAPV using is the economy question. The electric power consumers prefer the cheapest power source, if it possible. They compare various possibilities of the power supplying. In the case of the possibility choosing between the power supplying from EPS or from SAPV, this problem is concentrate on investment and operation costs of the power supplying system. It means that it depends on investment SAPV costs, EPS investment and operation costs (which are the function of the distance from distribution grid – Fig. 2)

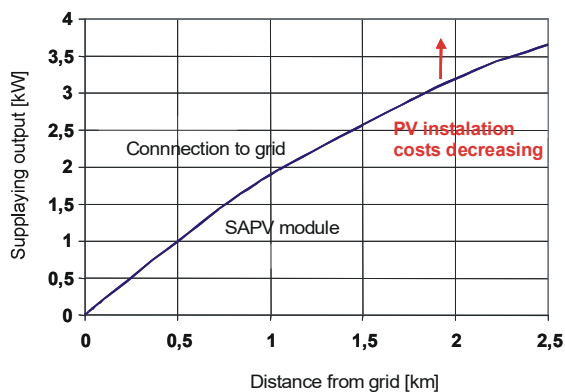

Figure 2. SAPV economy

In SAPV systems, special attention must pay to malfunction or failure. Start-up power peaks, or reactive power and harmonic distortion can cause system signal instability and protective devices will close the system down.

A well-matched load together with a carefully selected choice of appliances can lead to significant savings in terms of reduced need for PV and electricity storage capacity. Conversely, inefficient appliances and processes, standby loads and inappropriate loads will increase the requirement for expensive PV and storage capacity.

**Grid-connected distributed PV systems** (Fig. 3) are a relatively recent application where a PV system is installed to supply power to a building or other load that is also connected to the utility grid. These systems are increasingly integrated into the built environment and are likely to become commonplace. They are used to supply electricity to residential dwellings, commercial and industrial buildings, and are typically between 0,4 kW and 100 kW in size. The systems typically feed electricity

back into the utility grid when the on-site generation exceeds the building loads. These systems offer a number of advantages: distribution losses are reduced because the systems are installed at the point of use, no extra land is required for the PV systems, costs for mounting systems can be reduced, and the PV array itself can be used as a cladding or roofing material as 'building integrated PV' (BIPV). Compared to an off-grid installation, system costs are lower as energy storage is not generally required a factor that also improves system efficiency and decreases the environmental impact.

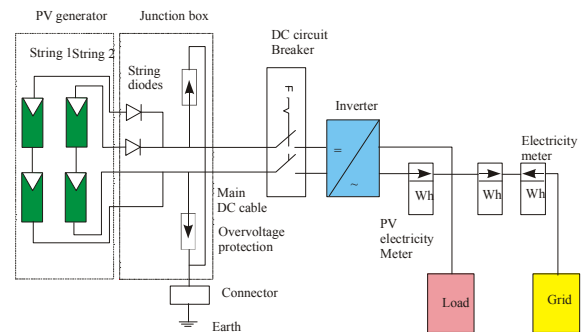

Figure 3. Grid on PV systems

Three types of grid-connected photovoltaic systems are considered in the Grid-Connected Photovoltaic System Design Review and Approval process. These include:

- *Grid-Connected PV Systems without Battery Storage,*
- *Grid-Connected PV Systems with Battery Storage,*
- *Grid-connected centralized systems.*

**Systems without battery** are designed to operate in parallel with and interconnected to the electric utility grid.

**Systems with battery** under normal circumstances operate in a grid-connected mode, supplementing the on-site loads or sending excess power back onto the grid while keeping the battery fully charged. In the event the grid becomes de-energized, control circuitry in the inverter opens the connection with the utility through a bus transfer mechanism, and operates the inverter from the battery to supply power to the dedicated critical load circuits only.

**Grid-connected centralized systems** have been installed for two main purposes:

- *an alternative to conventional centralized power generation,*
- *strengthening the utility distribution system.*

Utilities in a number of countries are investigating the feasibility of these types of power plants. Demonstration plants have been installed in Germany, Italy, Japan, Spain, Switzerland and the USA, generating reliable power for utility grids and providing experience in the construction, operation and performance of such systems.

In IPV (except centralised) systems, the power which flows from PV cells can fully or partly covers

the power consumption. In the case of the backward power flow to the EPS, the PV power cause electric power parameters changes. These changes are caused by inverters converting DC to AC. Inverters fall into two-main categories:

- *self-commutated*,
- *line-synchronised*.

The first can operate independently, being activated solely by the input power source; the line-synchronised inverters are triggered directly from the grid. Utilities require that inverters connected to the grid must contain suitable control and protection to ensure that systems are installed safely and do not adversely affect the power quality.

A major issue related to interconnection of distributed resources onto the power grid which can have the potential impacts on the quality of power provided to other customers connected to the grid can be described by the attributes which define power quality and include:

- **Voltage regulation** - The maintenance of the voltage at the point of delivery to each customer within an acceptable range.
- **Flicker** - The repetitive and rapid changes of voltage, which has the effect of causing unacceptable variations in light output and other effects on power consumers and their equipment.
- **Voltage imbalance** - The grid voltage does not have identical voltage magnitude on each phase, and a  $120^\circ$  phase separation between each pair of phases.
- **Harmonic distortion** - The injection of currents having frequency components which are multiples of the fundamental frequency.
- **Direct current injection** - A situation which can cause saturation and heating of transformers and motors, and can also cause these passive devices to produce unacceptable harmonic.

The maintenance of the voltage in supplying points in the definite limits s the problems related with the growing number connected PV generators to EPS. This is the main reason which limits penetration of PV systems in electric power networks.

### 3. VOLTAGE IN ELECTRIC POWER SYSTEMS

The supply voltage at the delivery point (I-J, Fig. 4) must lie within  $\pm 10\%$  of the nominal voltage for European LV networks according to EN 50160. Stricter limits may apply nationally, both in Europe and elsewhere. Accepted voltages typically lie between 90% and 106% of the nominal voltage. Stricter limits may apply nationally, both in Europe and elsewhere. Accepted voltages typically lie between 90% and 106% of the nominal voltage.

#### 3.1 The classic electric power system (centralised production)

In a classic EPS, the generated power of large centralised power generators supply the power network with electrical energy. The generators are

connected to the high voltage power network at the highest voltage level (A) and the power is consumed usually at the lowest voltage level (I-J) (see Fig. 4). The power flow causes the voltages to drop through the power system from the highest voltage to the lowest voltage.

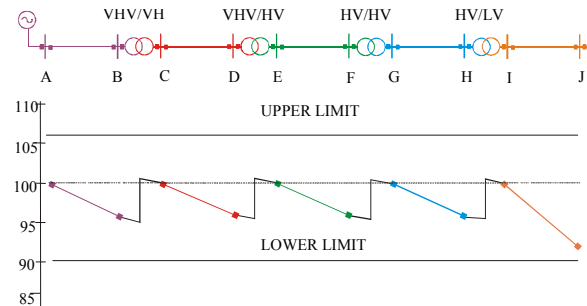

Figure 4. Voltage drops in the central supply EPS

The voltage changes caused by the loads switching on or off are regulate by the automatic tap changers on the secondary side of the transformers (except HV/LV) as close as possible to the nominal system voltage. The maximum deviation from the nominal system voltage is only  $\pm$  one step in tap changer position (typically  $\pm 1,5\%$ ).

#### 3.2 The decentralised electric power system with high PV penetration

In a decentralised EPS the power sources are interconnected to the EPS typically in the points of MV or LV levels. For the PV cells it is usually LV level due to their low power output.

As regards to EPS connection, usually, the MV/LV transformers are evenly distributed along an open MV ring (Fig. 5) and the PV cells can be interconnected to the system:

- **from a single LV line (A)** (in the order of 30-80 kWp power output),
- **from all the LV lines connected to a single MV/LV transformer (B)** (in the order of 200-400 kWp),
- **penetration from all the MV/LV transformers connected to MV ring (C)** (in the order of 1-2 MWp).

In each of these cases, the maximal penetration of PV cells is acceptable in depending on the voltage droop.

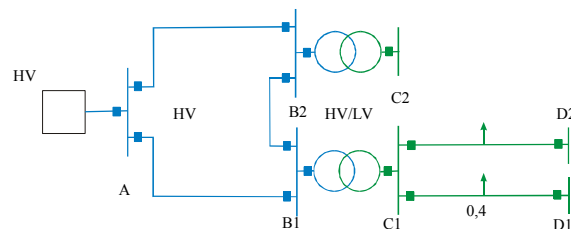

Figure 5. PV connection to EPS

The computation of PV penetration can be simplified and limited to the MV and LV due to automatic voltage regulation and therefore approximately 100 % voltage values in point A. The results are on Fig. 6. As the computation data, the typical values for the EPS scheme on Fig. 5. were assumed - five LV lines per MV/LV transformer, 10 MV/LV transformers per ring, average values for line impedances, line lengths and transformer sizes. The minimum load is set to 25% of the maximum load.

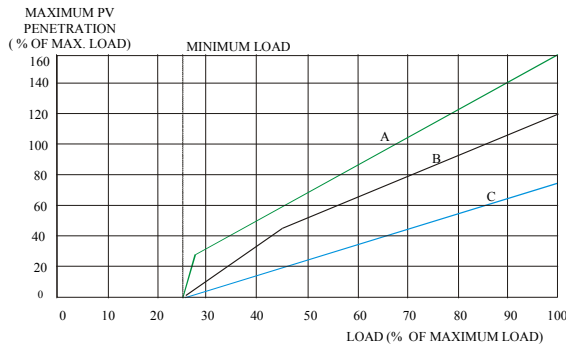

Figure 6. Maximal penetration PV in EPS

The results show that no PV penetration is acceptable at minimum load. However, the excess voltages are rather limited for PV penetrations up to the minimum load. In addition, only a small increase in the load from the minimum load opens up for a considerable amount of PV, especially if PV power only penetrates from a single LV line.

#### 4. POSSIBILITIES OF THE PV PENETRATION LIMITS STRETCHING

The purpose of PV cells interconnecting to EPS can follow two possibilities:

- *utilisation of the sun power as the renewable source* as much as possible,
- *maximal sun power utilisation on customer sides* with the acceptable economy and easy interconnection to EPS.

Maximal sun power concentration can be situated only to places with very high power density and their higher power output is interconnected to MV EPS.

In the case of PV interconnection on LV, usually, measures to increase the amount of PV penetration are only necessary if large power production from PV coincides with minimum load situations. This is the case during the summer holidays. The restrictions at minimum load are only a problem if the power generation from the PV systems coincides with minimum load situations.

##### 4.1 Separate PV reception networks

The separate reception networks for PV systems (i.e. PV networks separated from the consumer networks) is the solution of over-voltages from PV

penetration only for suitable places with good possibility to EPS interconnection. Such measures are often seen in the open country with high concentrations of wind power. The power networks are, however, not very often well established to begin within the open country. On the contrary, one of the big advantages of PV is in fact to connect to the existing power networks.

##### 4.2 Controllable PV systems

Another way to avoid over-voltages could be to let PV systems reduce their power generation in case of over-voltage. Such a measure would add unacceptable costs to PV systems, especially if the measure is not needed in the majority of cases. In addition, over-voltage monitoring systems would make PV more sensitive to short-term disturbances in the network.

Next, PV penetration can be assumed as one of distributed generation resources to the low voltage grids, such as, combined heat and power (CHP), micro-turbines, small wind turbines in certain areas and fuel cells. The number of these sources in the near future is constantly increasing and altering the traditional operating principle of the grids. A particularly promising aspect, related to the proliferation of small-scale decentralized generation, is the possibility for parts of the network comprising sufficient generating resources to operate in isolation from the main grid, in a deliberate and controlled way. Grid portions with such a capability are called Micro grids. A critical factor in order to exploit the potential offered by the micro grid concept is the presence of micro sources, with fast-acting power electronics interfaces to regulate voltage and frequency and ensure proper load sharing among the various sources, when operating in isolated mode. In interconnected mode, the micro-source and central micro-grid controllers regulate the power exchange with the grid, monitor grid conditions and ensure proper separation.

##### 4.3 Adjusting the transformer tap changer position

A more feasible solution to allow for more PV penetration at minimum load during summer days is to change the MV/LV transformer tap changer positions in the summer period when maximum load situations are not expected. Such a measure would require an interruption of the electricity supply twice a year for adjustment of the offload tap changers.

##### 4.4 Customer initiatives

One of the most efficient measures to allow for more PV is perhaps the customers' own changes of behaviour. Experience with PV systems shows that the customers change their consumption behaviour when at the same time they become power producers. Many customers who have PV installed

endeavour to move their consumption to moments with high power production from PV. This tendency is especially noticeable if the customers experience different buying and selling prices of electricity.

## 5. CONCLUSION

The limits to the amount of PV power that can be fed into a power system are least critical if the PV power penetrates from only a single LV line and they are more severe if PV power penetrates from multiple LV lines connected to the same MV/LV transformer or even multiple MV/LV transformers. The most severe limits occur in minimum load situations, especially if the power system beforehand is operated to its design limits. However, an amount of PV penetration equal to the minimum load only causes slight excess voltages in the power network.

In the longer term, it is expected that more flexible and accommodated consumption will remove the barriers of limits to PV penetration. It is essential that PV - together with other elements of distributed generation – is must be considered in the future network planning.

The work was supported by the GAČR (Czech Science Foundation), research project GAČR No. 102/02/0949.

## REFERENCES

- [1] Impacts of Power Penetration from Photovoltaic Power Systems in Distribution Networks Report IEA-PVPS T5-10: 2002.
- [2] Grid-connected photovoltaic power systems, Report IEA PVPS T5-03: 1999.
- [3] Dvorský, E., Hejtmánková, P., Mühlbacher, J.: Influence of photovoltaic cells interconnection to distribution power networks. 13<sup>th</sup> International expert meeting – Power Engineering, Maribor, Slovenia, 2004, ISBN 86-435-0617-6.
- [4] Dvorský, Hejtmánková, Tůma: Optimisation and reliability CHP units utilisation, International workshop “The Effective Use of Physical Theories of Conversion of Energy”, Permink, June n 2002.
- [5] Dvorský, Hejtmánková, Tesařová: Introduction of Distributed Generation Technologies, 12<sup>th</sup> International Expert Meeting "Power Engineering" Maribor, 2003.
- [6] Mühlbacher, J., Noháč, K., Noháčová, L.: Distributed power systems: 12<sup>th</sup> International Expert Meeting "Power Engineering" Maribor, 2003.

## BIOGRAPHY

**Jan Škorpil** was born on 18. 8. 1941. In the 1964 he received the M.Sc. (Ing.) degree with distinction at the Technical College in Plzeň, at the Department of Power machinery engineering. Then he worked as a plant engineer at the power and heating station of Chemical plant in Záluží. Since 1966 to 1971 he was a senior lector at the department of Power machinery engineering at the Technical College in Plzeň. Since 1971 to 1981 was a special worker for teaching technology, since 1981 he works at Power engineering department of Electric Engineering Faculty of the West Bohemia University in Plzeň. He finished PhD (CSc) study in the field of technical teaching in 1989. Since 1991 he is associate professor (Doc), his thesis title was from area of Power engineering. His branch area is power station equipment, renewable energy sources and environmental protection.

**Pavla Hejtmánková** finished her university study at 1987 in the specialisation of Electric Power Engineering. Then she worked as a assistant at Department of Power Engineering of Electric Engineering Faculty of West Bohemia University in Plzeň. In 1992 to 1995 continued in Ph.D. study in the field of Electric distribution network control.. She finished her Ph.D. study in 1996 and since she works as senior lecture on the same department. Now her research activity is concentrate to the Decentralised Sources utilisation.